

TEXIA
•1917•

ENVIRONMENTAL POLICY

Our commitment
to the environment

INDEX

OUR STORY

OUR MISSION AND VISION

OUR VALUES

OUR OWN UNIQUE, SUSTAINABLE
TEXTILE TECHNOLOGY

OUR COMMITMENT
TO USING
RENEWABLE MATERIALS

OUR INNOVATION

OUR PRODUCTION PROCESSES

ENVIRONMENTAL MANAGEMENT

OUR CERTIFICATION

OUR COMMITMENTS

A MESSAGE FROM OUR
CEO

OUR STORY

OUR STORY

The company was founded in the Poble Nou district of Barcelona in 1917 as a small textile finishing business.

More than 100 years later, we're still a textile company, made up of 90 people, and with our own technology that allows us to sell our products all over the world.

For us, sustainability is about guaranteeing the company's continued viability while also taking into account the planet's biophysical limits and the needs of current and future generations.

We want to contribute to sustainable development in the industry in line with the EU's environmental policies, the 2030 Agenda and the United Nations' Sustainable Development Goals (SDGs), with special emphasis on SDGs 8 and 12.



OUR MISSION AND VISION

MISSION

We're a family textile business that was founded in Barcelona in 1917. Thanks to our team's experience and our tradition of creativity and innovation, we create and manufacture products that are sold all over the world, and finish textiles for companies of all sizes.

By prioritizing honesty and transparency, we work to provide both the sector and society with value and reliability, guaranteeing professional freedom based on individual responsibility. We're excited to take on the task of contributing to making the textile sector more sustainable, for the sake of future generations.

VISION

We want to guarantee the sustainable growth of our family business by consistently developing new technology and new products.

OUR VALUES

QUALITY

Innovation is nothing without quality. We're in charge at every step of the manufacturing and sales process, which means we can create market-leading products for different sectors.

EXPERIENCE

100 years of experience and our in-depth knowledge of the textile industry allow us to work and grow alongside our clients. We offer clients a high-quality service across our areas of expertise.

CREATIVITY AND INNOVATION

We've spent more than a century innovating, perfecting and growing to set ourselves apart from the traditional textile industry. Our commitment to continuous improvement allowed us to overcome the industry-wide crisis and compete with Asian countries. And we're still going strong.

ADAPTABILITY

Our knowledge and technical skills allow us to quickly adapt to the needs of our clients and to economic and social change. That means we can develop new products and improve existing ones to offer better value.

SUSTAINABILITY

We use natural resources in a respectful and efficient way, and are always looking to improve. We do everything we can to minimize our impact on the environment and give back to society.



OUR OWN UNIQUE, SUSTAINABLE
TEXTILE TECHNOLOGY

OUR OWN UNIQUE, SUSTAINABLE TEXTILE TECHNOLOGY

SEAMLESS TEX TECHNOLOGY. PATENTED.

Our seamless technology allows us to remove certain steps from the production process, which makes us more competitive. And that means **we can reduce energy consumption and use fewer raw materials.** We have removed approximately 30% of the materials used for our seams, in comparison with other similar products.

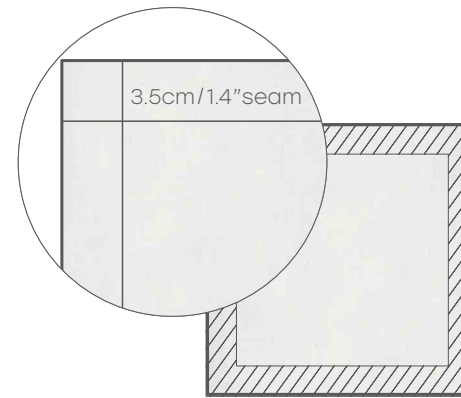

Tailored
textiles

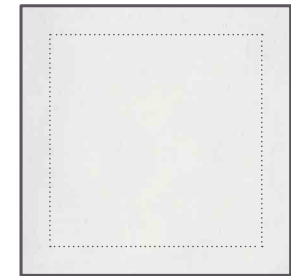

Textiles with SEAMLESS
TECHNOLOGY

**30% less
raw materials**



OUR COMMITMENT TO USING
RENEWABLE MATERIALS

OUR COMMITMENT TO USING RENEWABLE MATERIALS

100% NATURAL RAW MATERIALS

We're firmly committed to the use of high-quality natural fibers cultivated in a socially and environmentally responsible way. All our products are manufactured using renewable and biodegradable materials like cotton and linen.

We're part of the **Better Cotton Initiative (BCI)**, which aims to improve global cotton production for the people who produce it and the environment in which it is grown, to create a better future for the industry.

Likewise, we incorporate recycled cotton in some of our product ranges, promoting the circular economy and reducing environmental impact.

SUSTAINABLE PACKAGING

Our products are packaged using sustainable materials, such as FSC-certified cardboard.

We work to ensure that our products are distributed in packaging with the smallest environmental footprint.

OUR INNOVATION

R&D + ECO

We are constantly innovating to design new products and redesign classics to meet eco-friendly criteria.

We focus on **saving raw materials** (fabric or sewing thread) during the process of conceptualization, design and final product manufacturing.

The smaller the product, the more we save. Furthermore, our unique patented seamless technology removes the need for hemming, which in turn reduces the amount of fabric and thread used.

INNOVATION IN OUR PRODUCTS

- **Recycled cotton:** expansion of our range of recycled fabrics with GRS certification in the production of My Drap.
- **Compostable resin:** we have replaced the acrylic resin in the border of our My Drap products with a compostable option, which will be partially implemented starting in 2027.
- We are progressively working to expand the use of **compostable materials**, with the aim that, in the long term, all of our products will be compostable.



OUR PRODUCTION PROCESSES

RESPONSIBLE PRODUCTION

In our continuous improvement process, we control energy consumption, both gas and electricity, and water on a daily basis in our production lines.

This allows us to carry out an analysis of the impact of our activity and then apply improvement actions aimed at energy efficiency and the reduction of the water footprint.

INNOVATION IN OUR PRODUCTION PROCESSES

- **DryTech:** a recycled version of our DryTech cloth is currently under development.
- **Increased compostability:** we continue working to improve the compostability of our products.
- **Fluorine-free double-action treatment:** we are working on the development of placemats with a functional 'double action' treatment that is stain-resistant and oil-repellent, free of fluorine, with the aim of reducing the use of chemical substances and minimizing their environmental impact.

Our commitment to sustainability drives us to constantly innovate, seeking more responsible solutions for the planet.

ENVIRONMENTAL MANAGEMENT

WE ARE COMMITTED TO FULFILLING LEGAL REQUIREMENTS AND STANDARDS

We have an online system in place through which we can ensure legal compliance on environmental matters, as well as industrial safety and occupational risk prevention.

We have set out a Sustainability Plan for 2021-2025, with continuous improvement targets and measures that comply with the United Nations' 17 SDGs. We have the most restrictive state environmental license and every two years we carry out a full environmental inspection.

ENERGY EFFICIENCY

We have a cogeneration plant, thanks to which we can produce hot water and steam.

REDUCTION OF WATER CONSUMPTION

We clean our wastewater at our own treatment plant using physiochemical and biological treatments. This is then followed by a second treatment in a municipal wastewater treatment plant. We use water from local wells and carry out water quality controls.

EMISSION CHECKS

We check our emissions annually to ensure they are within legal limits.

WASTE MANAGEMENT

Our focus is on continually improving our waste segregation, recycling and recovery.

Members of the Better Cotton Initiative (BCI)

Improving global cotton production both for the people who produce it and for the environment it grows in, to create a better future for the sector.



Atmospheric emissions

We carry out annual reviews of our emission sources.

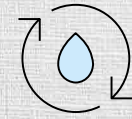

Water management

We carry out a daily control of the entire water circuit, we clean our wastewater and consume it.



100% natural raw materials

High quality socially and environmentally responsible raw materials.



R&D + ECO

We're always innovating to design new products and redesign classics to make them more environmentally friendly.



Factory

We have a cogeneration plant that allows us to reduce natural gas consumption.



Suppliers

We annually evaluate all our suppliers under sustainability standards.

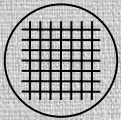

Texia-patented Seamless technology

Having no seams means one fewer link in our production chain. This reduces energy use.

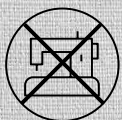

It saves on time, transport and labour.



Local production

Our facilities are located in Barcelona province and comply with European regulations.



Waste management

We continuously improve the segregation, recycling and recovery of our waste.



OUR CERTIFICATION

CERTIFICATIONS



GOTS

The world-leading standard for the certification of textiles made with organic fibers in accordance with strict environmental criteria.

GOTS: EGL/192987



OEKO-TEX STANDARD 100®

A world-renowned system that checks there are no harmful substances in textiles or at any stage in a product production.

OEKOTEX: 2021OK179

Member of the BCI



The Better Cotton Initiative (BCI) program's aim is to improve global cotton production for the people who produce it and the environment in which it grows to create a better future for the industry.



GRS

Our Global Recycled Standard (GRS) certification complements our Recycled Claim Standard (RCS) certification and guarantees that textile materials are recycled in compliance with environmental and social criteria.

GRS: EGL/192987



ISO 14001:2015

This certification recognizes the growing importance of the way companies manage their processes from an environmental point of view, and sees leadership as key to the proper functioning of the Environmental Management System.

ISO: M.0278.23



Compostability

The compostability certificate issued by AITEK guarantees that a product, container or material is biodegradable in a composting medium, with the final product being suitable for use as compost.

Compostability: 2024AN0036

OUR CERTIFICATION

CERTIFICATIONS IN PROCESS



STeP by OEKO-TEX®

Certification system that provides differentiation and distinguishes the company in the textile chain for its commitment to sustainable production.

ISO 9001:2015

It highlights the importance of quality management in business processes and promotes an approach based on continuous improvement, customer satisfaction, and operational efficiency. It also considers leadership and management commitment as key elements for the proper functioning of the Quality Management System.



MADE IN GREEN

The most demanding certification that currently exists in terms of health, environmental sustainability and corporate social responsibility, which guarantees the final consumer that the certified items do not contain chemical substances harmful to health and have been manufactured respecting the environment and the human rights of consumers workers.

OUR COMMITMENTS

At TEXIA, **we work to continually improve** by implementing new ways to reduce our environmental impact.

This Environmental Policy manifests TEXIA GUASCH GROUP's leadership in sustainability strategy as well as our firm's commitment to protecting the environment.

As part of our key **sustainability commitments** for the coming years, we include actions to mitigate our emissions, minimize water and chemical consumption, and exclusively utilize raw materials from sustainable sources.

Commitments undertaken:

Decarbonization:

- Reduce Scope 1 and 2 emissions associated with our production process by 30%.

Raw Materials:

- All our cotton is BCI-certified.

Commitments we've made for this period:

Decarbonization:

- Reduce Scope 1 and 2 emissions associated with our production process by 80%.

Raw Materials:

- 100% recycled fibers in all our products by 2030.

A MESSAGE FROM OUR CEO



At TEXIA, it has been clear to us for many years that sustainability is not an empty concept to which we are obliged to resort, but the core of our decalogue of 'mission, vision, value'.

Since I took over the company together with my brothers, it has been clear to us that we had to grow, but not in any way or at any price. A mission that seemed almost impossible in a sector like the textile industry, where some elements of the value chain were outside our area of influence.

A few years later, I can proudly say that we have succeeded. Today we have almost total control of the value chain and can more consistently apply the values we believe in. At the same time, because of our non-conformist nature, we are convinced that there is still a long way to go.

TEXIA is a company in constant evolution, especially in the search for efficiency in processes and in the final product through innovation. We are manufacturers and we are driven by the desire to do more with less and to optimise our production models. We are also driven by seamless technology, the element that gives meaning to the company.

We are facing an exciting challenge and we are looking forward to it with great enthusiasm. I am proud to be at the front of a talented and enthusiastic team that is convinced that we are on the right way. Without that conviction, it would be impossible to take on the purpose that drives us as a company.



Marlos Gvasch



**TEXIA
GUASCH
GROUP**

Updates to our
Environmental Policy to
reflect the 17 SDGs

**TEXIA
GUASCH
GROUP**

ISO14001
Certification

.....
**TEXIA
SEAMLESS**
.....

Compostability
Certification for our
My Drap products

2021

2022

2025

2027

2030

.....
**TEXIA
SEAMLESS**
.....

We have substituted
99% of the conventional
cotton used as a raw
material for BCI cotton

.....
**TEXIA
SEAMLESS**
.....

We have substituted
100% of the conventional
cotton used as a raw
material for BCI cotton

**TEXIA
FINISHING**

We have reduced the
emissions associated
with our production
process by 30%

**TEXIA
FINISHING**

We have reduced the
emissions associated
with our production
process

TEXIA
• 1917 •

Pol. Ind. El Mas s/n 08691 | Monistrol de Montserrat
Barcelona | Spain | +34 938 350 635

info@texia.com
texia.com